



gMV1616

UltraMatrix HDMI/Audio Switcher

INSTALLATION MANUAL

English

Specifications

INPUTS & OUTPUTS	
Source Inputs	
HDMI	16 w/ audio breakout
HDBaseT ARP	16 incl. with HDBaseT
Analog Audio	16 pr RCA connector
Digital Audio	16 ea Optical SPDIF 16 ea RCA Coaxial SPDIF
Zone Outputs	
HDBaseT	16 RJ45 Cat5e/Cat6/Cat7
HDMI (mirrored to HDBaseT)	16 19pin standard HDMI
Analog Audio	16 pr RCA connector
Digital	16 ea RCA Coaxial SPDIF
AUDIO	
Analog Inputs	
Input Sensitivity	0-2Vrms
Lip Sync	0-170ms in 1ms increment
Analog Outputs	
Volume Adjustment Range	-99.5dB to 0dB
Format Conversion	2ch PCM to analog
Lip Sync	0-170ms in 1ms increment
Tone/EQ Range	-20dB to +20dB in .5dB increment
Digital Inputs - Optical & Coaxial	
Format	Dolby 5.1, DTS, PCM Stereo
Format Conversion	2ch PCM to Analog stereo D/A
Lip Sync	0-170ms
Digital Outputs-Coaxial & HDMI	
Format	PCM (7.1ch) SPDIF from digital inputs
Format Conversion	2ch SPDIF from analog sources (requires mirror of analog zone output)
Lip Sync	0-170ms (requires mirror of analog zone output)
Tone/EQ	Bass/Treble/5 band (requires mirror of analog zone output)
HDMI Pass Through	Format – All audio formats including: PCM (7.1ch) SPDIF, Dolby® Digital & True HD, DTS-HD® & Master Audio
VIDEO	

HDMI Inputs/Outputs	<ul style="list-style-type: none"> ▪ HDMI 1.4a compliant ▪ 3D capable ▪ 36 bit deep color ▪ HDCP 1.1 compliant ▪ 6.75 Gps data rate ▪ 1080p, 1920x1080@60Hz, HDTV compatible 340MHz up to 16 bit Y-U-V 444 supported @ 1080p/60)
HDBaseT Outputs	<ul style="list-style-type: none"> ▪ HDMI compliant to v1.4a ▪ 3D capable ▪ Refresh rates 24Hz, 30Hz, 60Hz ▪ Uncompressed video resolution 1080p, 1920x1200 ▪ Deep Color 24-48 bit ▪ Vertical Frequency Range 50 – 60 Hz ▪ Digital Audio PCM/7.1ch formats including Dolby Digital, ▪ True HD, DTS-HD & Master Audio
Zone Outputs	Bi-directional serial and IR, Ethernet
Chassis Control	Ethernet, Serial RS-232
GENERAL	
Dimensions (8U)	17" x 14" x 14" 431.8 x 355.60 x 355.60 mm
Included in box	(1) ea US power cord (1) ea EU power cord (1) installation manual (1) contact trigger connector
Certifications	CE, UL, IC, FCC
POWER	
Mains supply	120/240 V~, 50Hz/60Hz, 5A max
Power Consumption	<p>Mains off: < 0.01W Networked standby, RS-232 only connected: < 0.5W Networked standby, TCP/IP only connected: < 1.0W Networked standby, RS-232 & TCP/IP connected: < 1.0W</p> <p>Automatic networked standby mode is activated 10 minutes after loss of control signal via Ethernet control port or RS-232 control port.</p>

Specifications and descriptions subject to change due to product upgrades and improvements.

Preface

Purpose of this Manual

This manual provides step-by-step installation instructions and connection examples, along with basic user information for installation and ongoing use of the ELAN gMV1616. This manual is written for the installer of this gMV1616 UltraMatrix Switcher.

Please see the software tutorial and Help file for programming information. These can be found at www.elanhomesystems.com.

Organization

The following information is contained in this manual.

Safety Information	Provides a comprehensive list of safety practices and procedures allowing for the safe installation and operation of ELAN gMV1616 UltraMatrix Switcher.
gMV1616 Introduction	Provides an introduction to ELAN' gMV1616 UltraMatrix Switcher, along with system features to include Front and Rear panel controls, indicators and connections, along with a short description of each.
gMV1616 System Design Overview	Provides a system design application overview of the gMV1616 UltraMatrix Switcher for use in audio, video and automation applications.
gMV1616 Connections	Provides a description of the gMV1616 UltraMatrix Switcher system connections to connections made with an ELAN gSC series system controller.
Troubleshooting	Provides troubleshooting tables to help fix common discrepancies that may be associated with the gMV1616 UltraMatrix Switcher.

Important Safety Instructions

1. Read these instructions.
2. Keep these instructions.
3. Heed all warnings.
4. Follow all instructions.
5. Do not use this apparatus near water.
6. Clean only with a dry cloth.
7. Do not block any ventilation openings. Install in accordance with the manufacturer's instructions.
8. Do not install near any heat sources such as radiators, heat registers, stoves or other apparatus (including amplifiers) that produce heat.
9. Do not defeat the safety purpose of the polarized or grounding-type plug. A polarized plug has two blades with one wider than the other. A grounding-type plug has two blades and a third grounding prong. The wide blade or the third prong is provided for your safety. If the provided plug does not fit into your outlet, consult an electrician for replacement of the obsolete outlet.
10. Protect the power cord from being walked on or pinched, particularly at plugs, convenience receptacles and the point where they exit from the apparatus.
11. Only use attachments/accessories specified by the manufacturer.

12. Use only with the cart, stand the cart/apparatus combination to avoid injury from tip-over.



13. Unplug this apparatus during lightning storms or when unused for long periods of time.

14. Refer all servicing to qualified service personnel. Servicing is required when the apparatus has been damaged in any way, such as power supply cord or plug is damaged, liquid has been spilled or objects have fallen into the apparatus, the apparatus has been exposed to rain or moisture, does not operate normally, or has been dropped.

15. Do not expose this apparatus to dripping or splashing and ensure that no objects filled with liquids, such as vases, are placed on the apparatus.

16. To completely disconnect this apparatus from the AC Mains, disconnect the power supply cord plug from the AC receptacle.

17. The power supply cord (sometimes referred to as the "Mains Plug") is used as the disconnect device and shall remain accessible and operable at all times.

18. Open flame sources, such as lighted candles, should NOT be placed on the apparatus.

19. Protective earthing terminal. The apparatus should be connected to a mains socket outlet with a protective earthing connection.



WARNING: To reduce the risk of fire or electric shock, do not expose this apparatus to rain or moisture.

The lightning flash with arrowhead symbol, within an equilateral triangle, is intended to alert the user to the presence of uninsulated "dangerous voltage" within the product's enclosure that may be of sufficient magnitude to constitute a risk of electric shock to persons.



The exclamation point within an equilateral triangle is intended to alert the user to the presence of important operating and maintenance (servicing) instructions in the literature accompanying the product.



FCC Required Text:

NOTE: This equipment has been tested and found to comply with the limits for a Class B digital device, pursuant to part 15 of the FCC Rules. These limits are designed to provide reasonable protection against harmful interference in a residential installation. This equipment generates, uses, and can radiate, radio frequency energy and, if not installed and used in accordance with the instructions, may cause harmful interference to radio communications. However, there is no guarantee that interference will not occur in a particular installation. If this equipment does cause harmful interference to radio or television reception, which can be determined by turning the equipment off and on, the user is encouraged to try to correct the interference by one or more of the following measures:

- Reorient or relocate the receiving antenna.
- Increase the separation between the equipment and receiver.
- Connect the equipment into an outlet on a circuit different from that to which the receiver is connected.
- Consult the dealer or an experienced radio/TV technician for help.

Changes or modifications not expressly approved by the party responsible for compliance could void the user's authority to operate the equipment.

Table of Contents

Specifications.....	1
Preface	
Purpose of this Manual.....	2
Organization.....	2
Safety Information.....	3
Chapter 1:	
Introduction.....	5
The ELAN Story.....	5
gMV1616Features.....	6
gMV1616 Functions & Indicators	7
gMV1616 Rear Panel Connections.....	8
gMV1616 EDID Table.....	13
Chapter 2:	
System Design and Applications.....	17
Applications Examples	18
Troubleshooting	20

Chapter 1:



Introduction

The gMV1616 UltraMatrix is the culmination of years of ELAN experience in the design and perfection of multi-zone audio and video switching. Incorporating the features and reliability that has made ELAN the fastest-growing manufacturer of multi-room A/V products, the UltraMatrix series of switches are ELAN's most powerful and flexible multi-source/multi-zone controllers to date. Each UltraMatrix switcher seamlessly blends HDMI routing along with full audio distribution. In fact, the UltraMatrix switchers provide more options for audio distribution than any previous product. UltraMatrix switchers work exclusively on the ELAN g! control network.

This unit has been designed with ultimate flexibility in mind. In addition to the analog, optical digital and coaxial digital audio inputs each UltraMatrix switcher allows the audio from HDMI inputs and the Audio Return Path (ARP) of each HDBaseT output to be easily routed to zone outputs. Zone outputs include analog, coaxial digital, HDBaseT and HDMI. The ELAN UltraMatrix switchers have an extensive feature set that is covered in detail in the UltraMatrix Designers Guide and the ELAN gMV Configurator Training Guide.

The ELAN Story

Located in Petaluma, CA, USA, ELAN is a part of Core Brands, LLC a Nortek Company. Sister companies within Core Brands include Niles, Xantech and Panamax/Furman. You may see references in this document to products from those brands. ELAN has designed innovative multi-room audio/video systems since 1989. ELAN systems were the first to integrate music, intercom and TV distribution features that used the homeowner's stereos, televisions and telephones to create the whole-house entertainment experience. These systems allow people to move from room to room, controlling centrally located equipment with ease.

ELAN's product line includes:

- System Controllers
- Power Amplifiers
- Multi-Zone Controllers
- Intelligent Keypads
- In-Wall Color Touch Panels
- Intercom Controllers
- Source Components
- Accessories for System Installation
- Lighting Control

gMV1616 Features

- **16 HDMI In x 16 HDMI/HDBaseT out**
Video switching for larger projects
- **Analog, Optical & Coaxial SPDIF Inputs**
Connect virtually any source
- **Analog & Coaxial SPDIF Outputs**
Connect power amplifiers or surround sound receivers
- **HDMI Audio Decoupling**
Audio from video sources may be routed to audio only zones
- **HDMI & HDBaseT Mirrored Outputs**
Two displays may be connected to any video output
- **Lip Sync Adjustment**
Digital delay may be added to any source or zone output in any combination up to 170ms
- **Analog Output Flexibility**
Analog outputs may be configured for stereo, dual mono, dual left or dual right
- **Zone Grouping Flexibility**
Zones may be members of Whole House Music, Area Groups or permanently Grouped
- **Designed For Use With The ELAN HDRE and HDRS HDBaseT Decoders**
The UltraMatrix Switchers were developed in conjunction with the HDRE and HDRS HDBaseT receivers to maximize performance
- **Much, Much More**
The list of UltraMatrix features is so large we had to create its own document. Visit the ELAN website to download the latest copy of the UltraMatrix Designers Guide

Included In Box

- 1 ea gMV1616
- 1 ea U.S. IEC Standard Power Cable
- 1 ea E.U. IEC Standard Power Cable
- 1 ea Contact Trigger Connector
- 1 ea Instruction Manual (this document)

gMV1616 Features



Figure 1 1: gMV1616 Front Panel Controls and Display

Item	Function	See Page
A	Control LED Blinks when control commands are received or sent	20
B	Thermal LED Displays when the chassis temperature has exceeded limits	20
C	Communication LED Displays when a valid TCP/IP connection is not available	20
D	Power LED Indicates power is connected to the chassis and the Mains Switch is ON	20

gMV1616 Rear Panel Connections

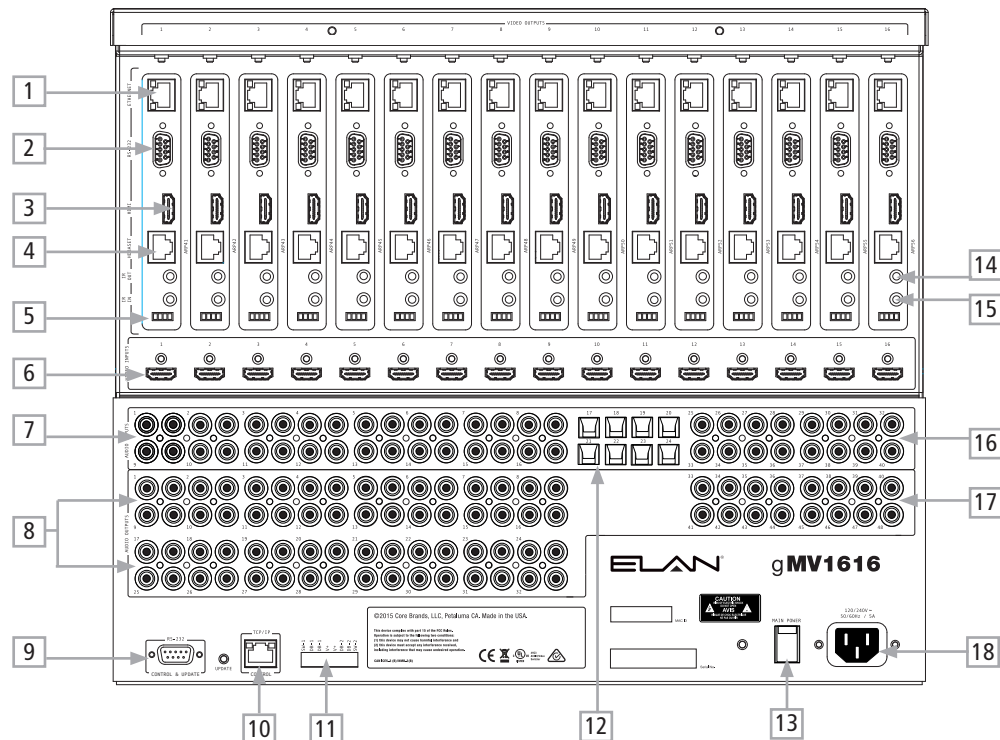

Item	Function	See Page	Item	Function	See Page
1	Ethernet (typ. of 16) Zone specific Ethernet connection	11	11	Control connection Contact trigger inputs – For Future Use	12
2	Serial Connection (typ. of 16) Zone specific RS-232 serial connection	11	12	Optical SPDIF Input (typ. of 8) Optical digital source inputs	9
3	HDMI Output (typ. of 16) HDMI zone output – mirrors HDBaseT	10	13	Main Power Switch Master power disconnect for chassis	12
4	HDBaseT Output (typ. of 16) HDBaseT zone output – mirrors HDMI Returns ARP signal	10	14	IR Output (typ. of 16) Zone specific IR return	11
5	HDBaseT output status (typ. of 16) Provides visual feedback of HDBaseT output status	20	15	IR In (typ. of 16) Zone specific IR input	11
6	HDMI Input (typ. of 16) HDMI source inputs	9	16	Coaxial SPDIF Input (typ. of 16) Coaxial digital source inputs	11
7	Analog Audio Input (typ. of 16) Stereo analog source inputs	9	17	Coaxial SPDIF Output (typ. of 16) Coaxial digital source output	9
8	Analog Zone Audio Output (typ. of 32) Connect to system amplifier. Outputs may be	10	18	IEC Power Cord Connection Connect IEC standard power cords 120v-240v	12
9	RS-232 Control and update connection	12			
10	TCP/IP Control connection	12			

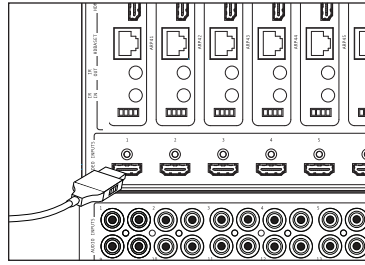

Figure 1 X3 HDMI Connection

Basic Inputs

This UltraMatrix switch can accommodate most common audio / video wired signals.

HDMI (6) – The UltraMatrix switcher can separate digital audio imbedded in the HDMI connection and route it to both analog and digital zone outputs. HDMI sources are connected to one of the HDMI Input connectors.

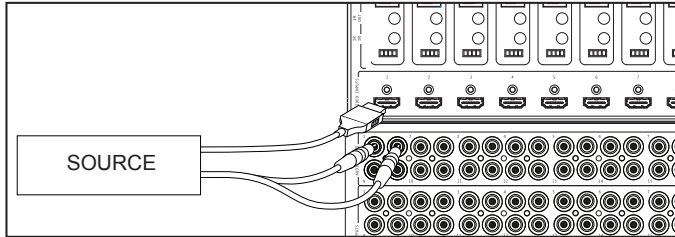

Figure 1-X5 Bi-wiring an HDMI source

When the source is configured for 2-ch audio output the UltraMatrix switcher will route the signal to both digital and analog outputs. Multi-channel signals cannot be routed to analog outputs. If both multi-channel and 2-ch signals are required the source must be bi-wired and both connections configured as unique sources in g! Configurator.

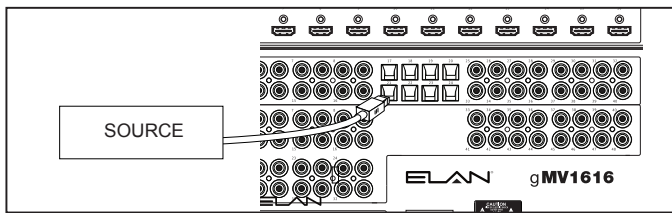

Figure 1-X6 Connecting an Optical Digital Audio source

Analog (7) – Analog inputs on the UltraMatrix switchers are used in pairs. If you have a mono source make sure to connect it to both the left and right inputs. Analog inputs may be routed to any analog or digital output.

Optical SPDIF (12) – Digital inputs are available for routing to both analog and digital outputs.

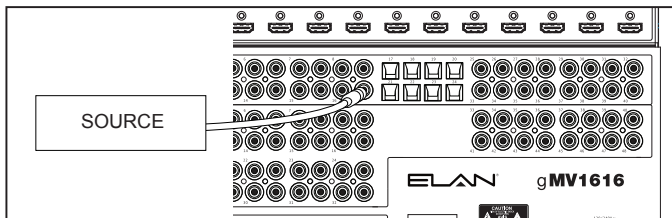

Figure 1-X7 Connecting a Coaxial Digital Audio source

When paging/door chime is enabled in the ELAN g! Configuration Software for distribution over the whole house audio speakers analog input 16 is used.

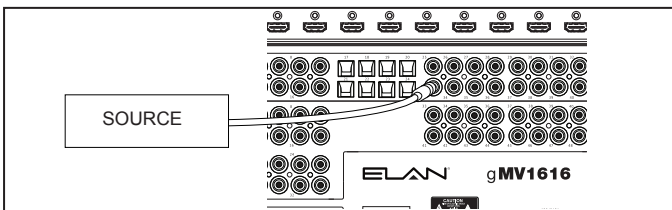

Figure 1-X8 Connecting a Coaxial Digital Audio source

Coaxial SPDIF (16) – Digital inputs are available for routing to both analog and digital outputs.

It is generally preferred that Audio Only sources are connected digitally as digital signals present no compromises to signal routing. Connected digital sources should be configured for 2 CH PCM output to assure full compatibility.

Basic Outputs

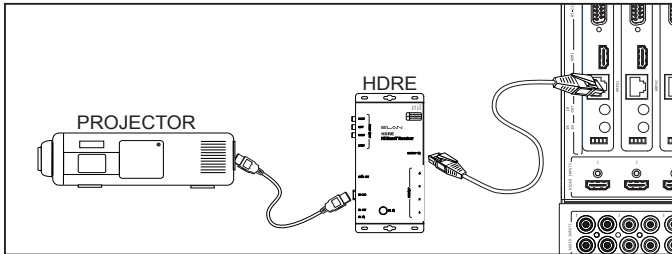

Figure 1-X9 Connecting an HDBaseT output

HDBaseT (4) – HDBaseT outputs combine HDMI, digital audio, bi-directional serial, bi-directional IR, 10/100 Ethernet and ARP signals along with voltage to power the HDRE onto a single Cat5e/6/7 wire. The HDBaseT standard allows wiring lengths up to 100m (328’), although the use of ARP reduces the maximum wire length by 15m (50’). Terminate wiring with T568B RJ45 connectors rated for the type of wiring you have run. Test all terminations prior to connecting to the UltraMatrix switcher.

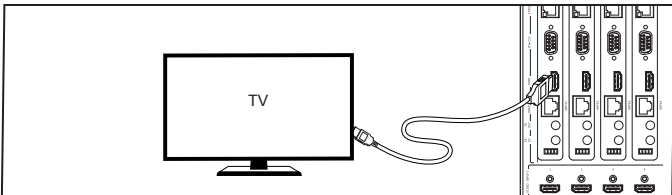

Figure 1 X10 Connecting an HDMI output

HDMI (3) – The UltraMatrix switcher features mirrored HDMI and HDBaseT outputs. Advanced EDID management allows both of these outputs to be active at the same time. Connect the HDMI output to a monitor using appropriate quality HDMI cables.

NOTE: When connecting displays to both the HDMI and HDBaseT outputs the audio EDID information will always be read from the device connected to the HDMI output and the video EDID information will always be read from the device connected to the HDBaseT receiver HDMI output.

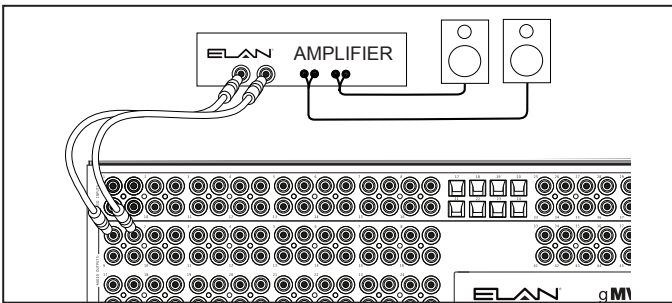

Figure 1 X11 Connecting an Analog Audio Zone Output

Analog* (8) – Analog outputs are connected to amplifiers and may be configured as stereo, dual mono, dual left channel or dual right channel. They may be grouped in various configurations (see Zone Grouping Options on page 17)

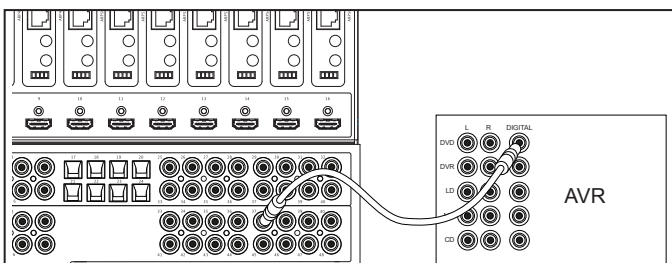

Figure 1 X12 Connecting an Analog Audio Zone Output

Coaxial SPDIF* † (17) – Digital outputs generally connect to surround sound receivers.

* Only 2-ch PCM digital audio signals may be routed to the analog outputs. Multi-channel digital signals cannot be converted for use on analog outputs. Multi-channel digital audio signals may be routed without compromise to digital and HDMI outputs.

When analog inputs are routed to digital outputs the digital output and an analog output mirror each other

Digital Output #	Mirrors Analog Output #
17	1
18	2
19	3
20	4
21	5
22	6
23	7
24	8
25	9
26	10
27	11
28	12
29	13
30	14
31	15
32	16

† Digital zone outputs configured to access analog inputs create a mirrored digital and analog output situation. The g! configuration software will manage the situation and you can refer to this chart to make sure that you do not mis-connect an output.

When Digital outputs are configured to mirror Analog outputs the output level becomes variable and matches the output level of the analog outputs.

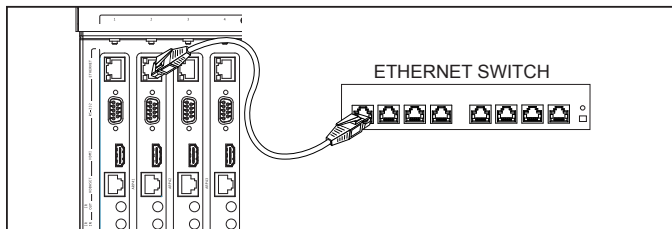

Figure 1 X13 Connecting an Ethernet jumper to the HDBaseT (Zone 2 showed for example)

HDBaseT Distribution Connections

Ethernet (1) – Each zone output has a connection for 10/100 Ethernet. Connection to an Ethernet switch should be done with appropriately rated cable and need only be made if you are going to utilize Ethernet at the destination room for a Smart TV, game station, media player or the like. Ethernet signal distribution over HDBaseT requires use of the ELAN HDRE as the HDBaseT receiver.

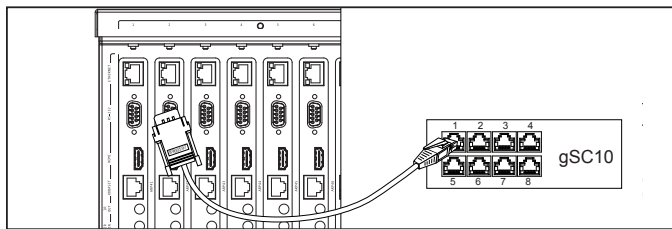
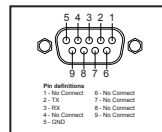

Figure 1 X14 Connecting Serial to the HDBaseT output (Zone 2 showed for example)

Serial (2) – Industry standard DB9 connectors are used to connect g! serial control signals to equipment at the destination room at baud rates up to 115K. Use ELAN part no. 8900597 to connect a CAT-5 cable directly from the g! controller output to the zone specific serial connector.



Serial RS-232 connector pin-out

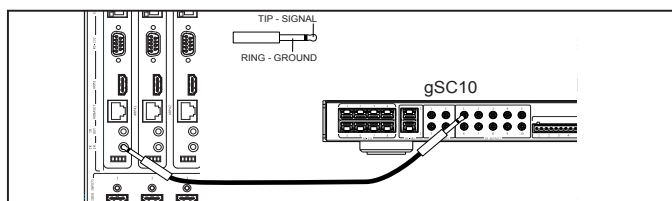

Figure 1 X15 Connecting IR to the HDBaseT output (Zone 2 showed for example)

IR In (15) – IR inputs are zone specific and are generally connected to g! controller IR outputs with a 1/8” (3.5mm) mono mini to 1/8” mono mini cable. Use this connection to operate monitors and sources in the destination room. g! controllers allow many sources to be connected to the same IR output, so as long as you do not have duplicate devices in the destination room you will have no problem operating several IR devices with one connection using an IR connecting block like the Xantech 789-44 on the IR output of the HDRE or HDRS.

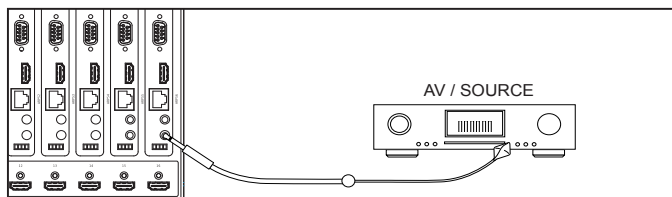

Figure 1 X16 Connecting HDRE to gMV with HDBST, and IR Out on GMV connected to g1 IR Input.

IR output (14) – zone specific outputs provide access to IR signals generated in the destination room. Unless you have connected an IR receiver to the HDRE HDBaseT receiver to control a centrally located g1 OSD interface it is unlikely you will utilize these connections. If you have an IR controlled device not related to the A/V system it is possible that this connection could be used for that.

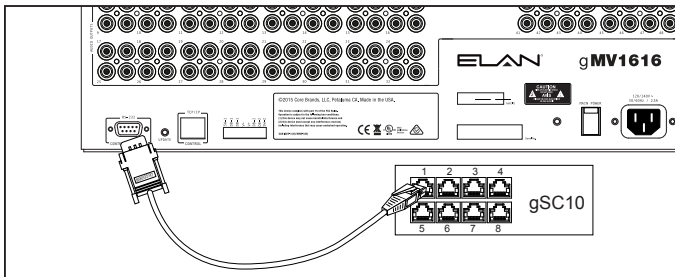

Figure 1 X17 Connecting Serial to the UltraMatrix RS-232 connector.

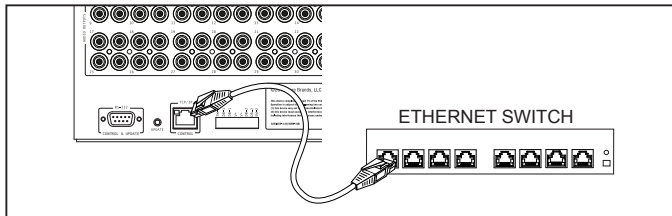

Figure 1 X18 Connecting an Ethernet jumper to the TCP/IP port

Other Connections

RS-232 Port (9) – Control and Update port. For ERP compliant installations use the serial port for control. Use ELAN part no. 8900597 to connect a CAT-5 cable directly from the g! controller. Connection along with g!Tools is also used to update the firmware on the UltraMatrix controller. You should only update firmware at the direction of ELAN Technical Support or a specific Technical Bulletin from ELAN.

TCP/IP (10) – Control port. Connect to the Ethernet switch. Chassis control over TCP/IP is possible. Connect the UltraMatrix to an available port on your Ethernet switch.

NOTE: The gMV1616 meets European (ERP) standby power requirements. The ERP circuit monitors the TCP/IP and RS-232 ports for communication with the g! controller and after 10 minutes of no communication will place the chassis in a low power consumption mode. In this mode the RS-232 connection is still active, but the TCP/IP connection is not.

The only way to wake the unit up from low power consumption mode is to send it a serial command over the RS-232 port or to cycle main power. When using the TCP/IP port to control the UltraMatrix chassis it is recommended that you do not turn the power on to the UltraMatrix until the g! controller has also been powered up.

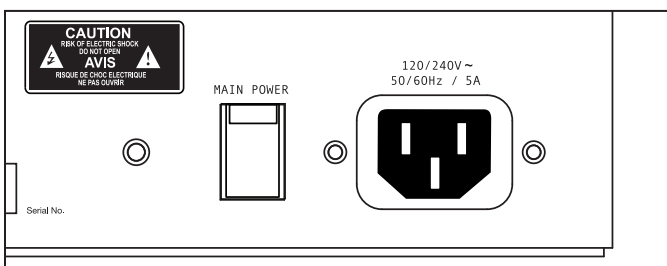

Figure 1 X19 Connect IEC standard power cords 120v-240v

Contact Triggers (11) – These connections are reserved for Future Use.

Main Power Switch (18) – Switching to OFF completely powers down the chassis. Make all system connections with the Main Power Switch in the OFF position. Switching to ON turns on the UltraMatrix chassis and illuminates the blue power LED (D) on the front panel. Power down system amplifiers before powering down the UltraMatrix switcher.

EDID Table

The UltraMatrix switchers utilize a table format to manage source and display EDID's. EDID's tell the source what video and audio format to output. Each source has a table and the capabilities of each display that the source may be routed to is included in the table. Once populated, the EDID table will direct the source to output the highest performance format that all displays and the source are compatible with. To assist with programming and troubleshooting EDID worksheets for video and audio are provided below.

INPUTS	VIDEO EDID WORKSHEET				
	480i	480p	720p	1080i	1080p
HDMI 1					
HDMI 2					
HDMI 3					
HDMI 4					
HDMI 5					
HDMI 6					
HDMI 7					
HDMI 8					
HDMI 9					
HDMI 10					
HDMI 11					
HDMI 12					
HDMI 13					
HDMI 14					
HDMI 15					
HDMI 16					

DEVICES

Fill in your devices and their capabilities. You may have to do a little digging to find the information you need for each device. The highest common resolution is what all displays with access to the source will be sent. Displays not compatible with the resolution may not display an image.

VIDEO EDID WORKSHEET

COMPATIBLE RESOLUTION

OUTPUTS	COMPATIBLE RESOLUTION				
	480i	480p	720p	1080i	1080p
HDMI 1					
HDBASET 1					
HDMI 2					
HDBASET 2					
HDMI 3					
HDBASET 3					
HDMI 4					
HDBASET 4					
HDMI 5					
HDBASET 5					
HDMI 6					
HDBASET 6					
HDMI 7					
HDBASET 7					
HDMI 8					
HDBASET 8					
HDMI 9					
HDBASET 9					
HDMI 10					
HDBASET 10					
HDMI 11					
HDBASET 11					
HDMI 12					
HDBASET 12					
HDMI 13					
HDBASET 13					
HDMI 14					
HDBASET 14					
HDMI 15					
HDBASET 15					
HDMI 16					
HDBASET 16					

DEVICES

Fill in your devices and their capabilities. You may have to do a little digging to find the information you need for each device. The highest common format is what all HDMI/HDBaset outputs with access to the source will be sent. Displays & AVR's not compatible with the format may not play sound.

EDID Table

The UltraMatrix switchers utilize a table format to manage source and display EDID's. EDID's tell the source what audio format to output. Each source has a table and the capabilities of each display that the source may be routed to is included in the table. Once populated, the EDID table will direct the source to output the highest performance format that all displays and the source are compatible with. To assist with programming and troubleshooting EDID worksheets for audio are provided below.

		AUDIO EDID WORKSHEET		COMPATIBLE RESOLUTION		
		INPUTS	2ch PCM	Dolby Dgt	DTS	DD TrueHD
D E V I C E S	HDMI 1					
	HDMI 2					
	HDMI 3					
	HDMI 4					
	HDMI 5					
	HDMI 6					
	HDMI 7					
	HDMI 8					
	HDMI 9					
	HDMI 10					
	HDMI 11					
	HDMI 12					
	HDMI 13					
	HDMI 14					
	HDMI 15					
	HDMI 16					

Fill in your devices and their capabilities. You may have to do a little digging to find the information you need for each device. The highest common resolution is what all displays with access to the source will be sent. Displays not compatible with the resolution may not display an image.

AUDIO EDID WORKSHEET

DEVICES

OUTPUTS	COMPATIBLE RESOLUTION				
	2ch PCM	Dolby Dgt	DTS	DD TrueHD	DTS Master
HDMI 1					
HDBASET 1					
HDMI 2					
HDBASET 2					
HDMI 3					
HDBASET 3					
HDMI 4					
HDBASET 4					
HDMI 5					
HDBASET 5					
HDMI 6					
HDBASET 6					
HDMI 7					
HDBASET 7					
HDMI 8					
HDBASET 8					
HDMI 9					
HDBASET 9					
HDMI 10					
HDBASET 10					
HDMI 11					
HDBASET 11					
HDMI 12					
HDBASET 12					
HDMI 13					
HDBASET 13					
HDMI 14					
HDBASET 14					
HDMI 15					
HDBASET 15					
HDMI 16					
HDBASET 16					

Fill in your devices and their capabilities. You may have to do a little digging to find the information you need for each device. The highest common format is what all HDMI/HDBaseT outputs with access to the source will be sent. Displays & AVR's not compatible with the format may not play sound.

Chapter 2:

System Design and Applications

System Design

The UltraMatrix family of switchers have a vast number of features with their own potential benefits to the end user. The description of features and the design requirements of each feature is covered in-depth in the UltraMatrix Designers Guide. Covered in this manual are just the features that affect the wiring of an UltraMatrix chassis.

Due to the vast number of possible UltraMatrix connections it is strongly recommended that you do not attempt to wire the chassis without a complete one-line document created by the system engineer. The following examples will provide a connection reference for the many of the configurations you are likely to see.

HDMI Audio Decoupling – The sound from HDMI inputs may be used as a source in audio only zones

HDMI & HDBaseT Mirrored Outputs – Advanced circuitry allows the UltraMatrix switchers to output HDMI signals simultaneously on both the HDMI and HDBaseT connections of each zone.

Audio Return Program (ARP) – HDBaseT provides a digital PCM audio return channel on each output. ELAN's implementation of this channel is unique and referred to as Audio Return Program (ARP). ARP utilizes separate inputs on the HDRE receiver to provide an audio input that is independent of the monitor. This input may be utilized for connection to any analog or digital source, and the source connected may be routed to any analog or digital output.

NOTE: When ARP is enabled (see HDRE instructions for enable/disable help) the maximum wire length for the HDBaseT signal is shortened to 260' (80m) if using CAT5e. If using CAT6 or CAT7 ARP does not affect wire length.

Lip Sync Delay – Each analog output has up to 170ms of delay that can be assigned to all sources routed to the output and/or to a specific source. Where you assign the delay depends on what is causing the video delay. If only a source is causing the delay, then applying the lip sync to the source only is appropriate. If the display or a video processor in-line with the display is causing the issue then delaying all sources routed to the zone would be appropriate. When a source with delay is selected in a zone with delay the delays are added and executed up to a maximum of 170ms. Lip sync is not available for multi channel digital outputs.

Analog Output Configuration – Analog zone outputs may be configured for stereo, dual left channel, dual right channel, dual mono, and stereo reverse.

Output Grouping – Zone outputs maybe grouped several ways;

- **Sub Zone** – Attaches one analog zone (sub) to another (master). The subzone tracks the master zone source but retains independent volume adjustment.
- **Zone Grouping** – establishes a set of outputs that can be easily grouped or un-grouped by the end-user. Outputs for outdoor areas, entertaining areas, or master suite rooms are good candidates for zone grouping.
- **Whole House Music (WHM)** – Zones are selected through the g! Configurator for inclusion or exclusion for WHM. The end user simply selects "Settings" in their current zone, then presses WHM On and all included zones are grouped to the active zones source.

Application Examples

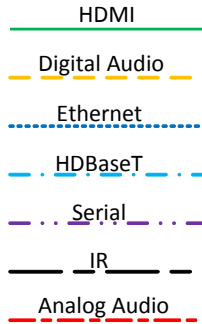

Advanced Connections

Basic connections were covered in the previous section. This section will provide hookup diagrams for some of the more common advanced distribution scenarios.

Application 1: Audio/Video Zone – Music and Video sound from WHA

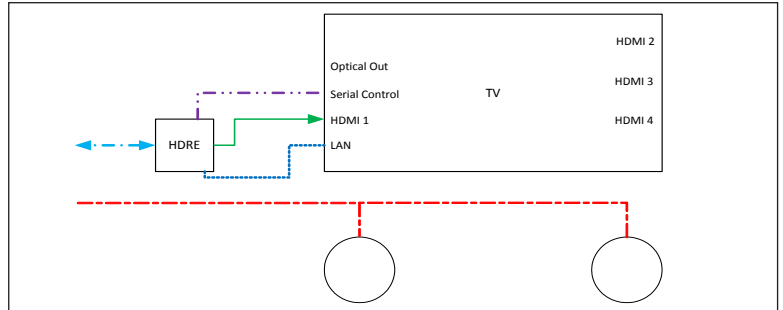

Application 2: Audio/Video Zone – Music and Video sound from WHA with TV as source (Netflix Streaming)

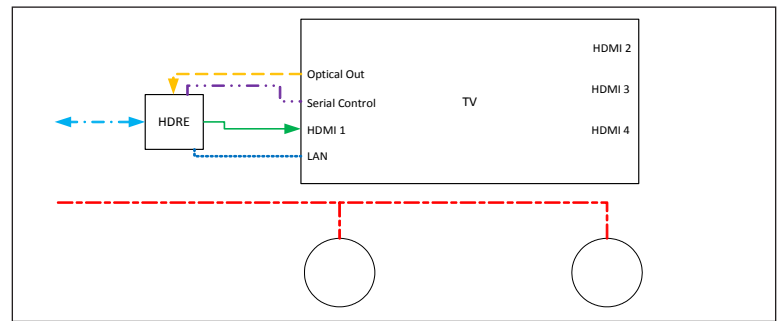

Application 3: Audio/Video Zone – Music and Video sound from WHA with local sources

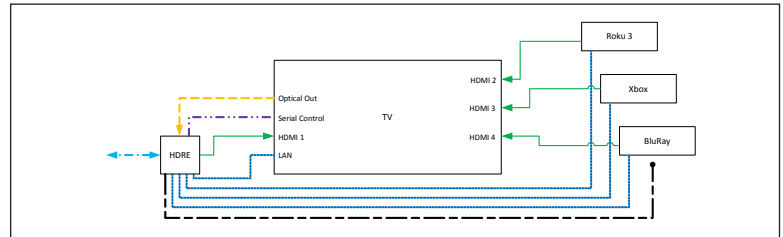

Application 4: Audio/Video Zone – Local audio source – TV sound from sound bar – music from WHA

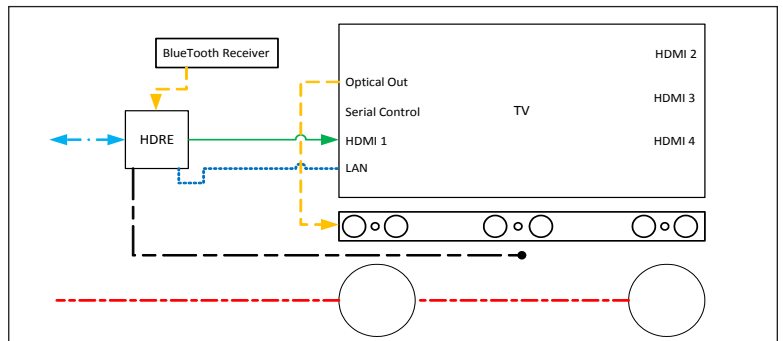

Application 5: Audio/Video Zone – TV plays music through sound bar as zone controller – requires TV on to listen to music

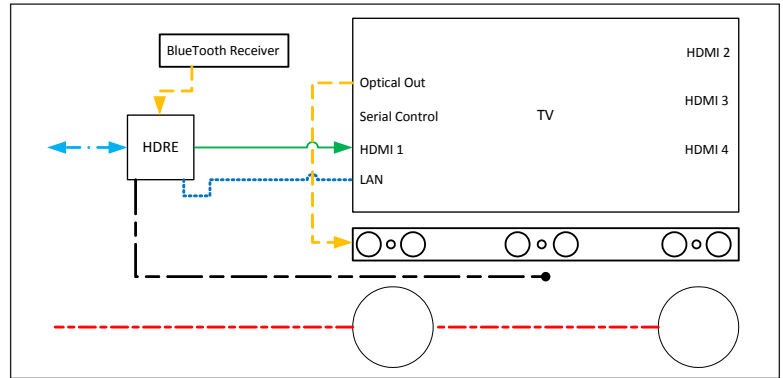
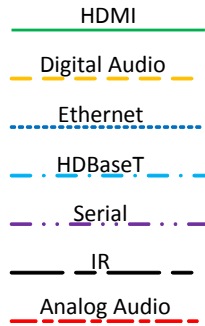

Application 6: Home Theater Zone – Remote zone with AVR, centralized and local sources

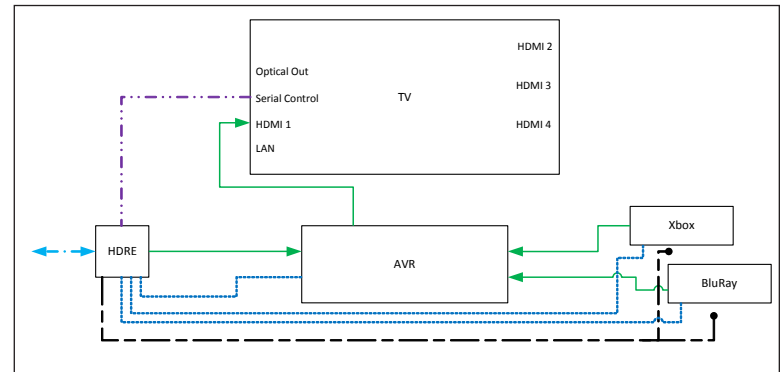

Application 7: Home Theater – Dual displays on same zone

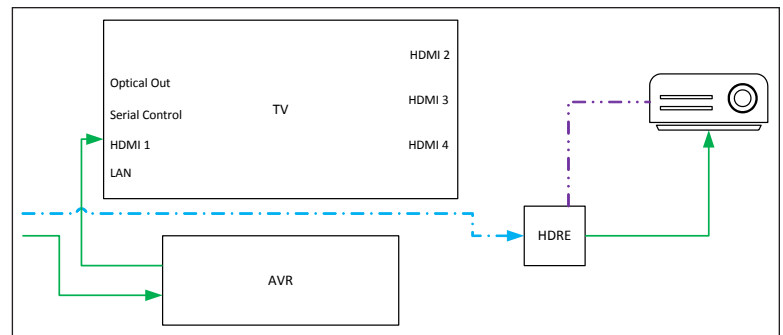

Application 8: Man Cave – 5 main displays with wet bar TV and AVR

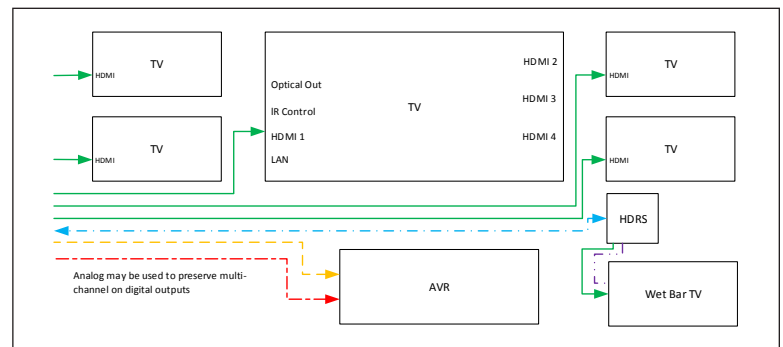

Troubleshooting

Table 1.1 Troubleshooting with the Front Panel LED's

Symptom	Possible Cause/s	What an authorized installer can do
Control LED Does not flash when control commands are sent from g! controller	<ol style="list-style-type: none"> 1. No power 2. No communication from controller 3. Controller not programmed 	<p>Check Main Power Switch on rear</p> <p>Confirm unit is plugged into an unswitched power outlet</p> <p>Check the circuit breaker</p> <p>Check control cabling Ethernet wiring</p> <p>Confirm Ethernet switch & router are functioning correctly if the UltraMatrix is connected via TCP/IP</p> <p>Program controller using g! Configurator</p>
Communication LED is lit	<ol style="list-style-type: none"> 1. A valid TCP/IP connection is not available 	<p>Check Ethernet wiring</p> <p>Confirm Ethernet switch & router are functioning correctly</p>
Thermal LED is lit	<ol style="list-style-type: none"> 1. Internal temperature of the UltraMatrix has exceed limits 	<p>Turn off unit for 30 minutes and allow to cool</p> <p>Re-arrange rack or cabinet to provide better air movement around the UltraMatrix chassis</p> <p>Add positive ventilation (fans or cooling kits) to cabinet/rack</p>
Power LED is dark	<ol style="list-style-type: none"> 1. No power 	<p>Check Main Power Switch on rear</p> <p>Confirm unit is plugged into an unswitched power outlet</p> <p>Check the circuit breaker</p>

Table 1.2 HDBaseT LED Troubleshooting

Symptom	Possible Cause/s	What an authorized installer can do
MODE LED (left or top most LED) is dark. Slow blink is normal operation.	<ol style="list-style-type: none"> 1. Mis-wiring 2. Bad patch cable 3. Too much wire 	<p>Verify with continuity tester that pairs are landed T568B (preferred) on both ends of the wire</p> <p>Replace cables with known good cables</p> <p>Verify that wire length does not exceed 328' (100m)</p>
LINK LED is dark. Is lit when a valid HDBaseT link is established.	<ol style="list-style-type: none"> 1. Invalid link between transmitter and receiver 2. Mis-wiring 3. Bad patch cable 4. Too much wire 	<p>Verify with continuity tester that pairs are landed T568B on both ends of the wire</p> <p>Verify with continuity tester that pairs are landed in either T568A or on both ends of the wire</p> <p>Replace cables with known good cables</p> <p>Verify that wire length does not exceed 328' (100m)</p>

Symptom	Possible Cause/s	What an authorized installer can do
HDCP LED is dark. (The LED is solid when a valid HDCP key is registered. The LED flashes when picture is present but an HDCP key is not required)	<ol style="list-style-type: none"> 1. The source is not a valid HDCP source 2. The display is not compatible with HDBaseT transmitted HDMI 3. Mis-wiring 4 Bad patch cable 5. Too much wire 	<p>Select a source with HDCP protected material</p> <p>Verify display has latest firmware for compatibility with HDBaseT</p> <p>Verify with continuity tester that pairs are landed T568B (preferred) on both ends of the wire</p> <p>Replace cables with known good cables</p> <p>Verify that wire length does not exceed 328' (100m)</p>
POWER LED is dark	<ol style="list-style-type: none"> 1. Mis-Wiring 2. Bad patch cable 3. Too much wire 4. UltraMatrix is not powered on 	<p>Verify with continuity tester that pairs are landed T568B (preferred) on both ends of the wire</p> <p>Replace cables with known good cables</p> <p>Verify that wire length does not exceed 328' (100m)</p> <p>Connect power and turn on the MAIN POWER switch</p>

Table 1.3 Audio and Video Troubleshooting

No picture on monitor	<ol style="list-style-type: none"> 1. Mis-Wiring 2. Bad Patch Cable 3. Too Much Wire 4. EDiD Table Mis-Match 	<p>Verify with continuity tester that pairs are terminated T568B on both ends of the wire</p> <p>Replace cables with known good cables</p> <p>Verify that wire length does not exceed 328' (100m)</p> <p>Double check your EDID table worksheet and g! Configurator source EDID settings</p>
No sound from Analog output	<ol style="list-style-type: none"> 1. Improper configuration 2. Illegal format 3. No communication with switcher 	<p>Verify the source is configured properly Multi-channel sources may not be routed to analog outputs</p> <p>Verify control of the UltraMatrix by observing the Communication LED</p>
No sound from Digital output	<ol style="list-style-type: none"> 1. Improper configuration 2. No Analog/Digital Mirror on zone output 	<p>Verify the source is configured properly</p> <p>An analog output must be mirrored for a digital output to receive analog sources</p>

Limited Warranty ELAN UltraMatrix HDMI/Audio Switcher

ELAN HOME SYSTEMS, LLC, a Core Brands, LLC company ("ELAN") warrants the UltraMatrix HDMI/Audio to be free from defects in materials and workmanship for the period of two years (2 years) from date of purchase. If within the applicable warranty period above purchaser discovers that such item was not as warranted above and promptly notifies ELAN in writing, ELAN shall repair or replace the item at the company's option. This warranty shall not apply (a) to equipment not manufactured by ELAN, (b) to equipment which shall have been installed by other than an ELAN authorized installer, (c) to installed equipment which is not installed to ELAN's specifications, (d) to equipment which shall have been repaired or altered by others than ELAN, (e) to equipment which shall have been subjected to negligence, accident, or damage by circumstances beyond ELAN's control, including, but not limited to, lightning, flood, electrical surge, tornado, earthquake, or other catastrophic events beyond ELAN's control, or to improper operation, maintenance or storage, or to other than normal use of service. With respect to equipment sold by, but not manufactured by ELAN, the warranty obligations of ELAN shall in all respects conform to the warranty actually extended to ELAN by its supplier. The foregoing warranties do not cover reimbursement for labor, transportation, removal, installation or other expenses which may be incurred in connection with repair or replacement.

Except as may be expressly provided and authorized in writing by ELAN, ELAN shall not be subject to any other obligations or liabilities whatsoever with respect to equipment manufactured by ELAN or services rendered by ELAN.

THE FOREGOING WARRANTIES ARE EXCLUSIVE AND IN LIEU OF ALL OTHER EXPRESSED AND IMPLIED WARRANTIES EXCEPT WARRANTIES OF TITLE, INCLUDING BUT NOT LIMITED TO IMPLIED WARRANTIES OF MERCHANTABILITY AND FITNESS FOR A PARTICULAR PURPOSE.

ATTENTION: TO OUR VALUED CONSUMERS

To ensure that consumers obtain quality pre-sale and after-sale support and service, ELAN Home Systems products are sold exclusively through authorized dealers. ELAN products are not sold online. The warranties on ELAN products are NOT VALID if the products have been purchased from an unauthorized dealer or an online E-tailer.

To determine if your ELAN reseller is authorized, please contact ELAN Home Systems at (707) 283-5900.

www.elanhomesystems.com

